

DIGITAL INDUSTRIES SOFTWARE

NX Mach design solutions

Prepackaged high-performance CAD solutions

Benefits

- Boosts product design efficiency
- Accelerates mechanical design processes
- Improves collaboration
- Reduces design process waste
- Improves design quality
- Single environment facilitates process from model to printed part

Features

- End-to-end mechanical product design solutions with a rich set of supporting tools
- High-performance modeling, drafting and comprehensive assembly design powered by synchronous technology and Convergent Modeling
- Comprehensive preconfigured solutions tailored for the full range of product design applications
- Power and flexibility that supports virtually any design methodology, whether top-down or bottom-up

Summary

The NX Mach™ software products are prepackaged solutions delivering high-performance computer-aided design (CAD) capabilities of NX™ software, the leading solution for mechanical design. They offer competitively priced solutions tailored to specific product development roles, practices and processes, in three performance tiers. Value-added upgrades are available to move customers from one tier to the next. Each package delivers complete capabilities for production work.

NX Mach 1, 2 and 3 solutions include everything needed to integrate with Teamcenter® software to provide optional extended engineering process management tools through scalable collaboration and advanced management.

All of the NX Mach design solutions share a common denominator of high-performance CAD functions and powerful high-definition 3D (HD3D) Visual Reporting, enabling designers and engineers to quickly understand key elements of their designs. Each level of the solutions builds upon the other, providing increasingly more sophisticated and advanced design capabilities.

NX Mach 1 Product Design

This entry-level solution offers tools for creating and editing designs of typical mechanical components and assemblies, with solid modeling and drafting, basic freeform modeling and sheet metal design. NX Mach 1 Product Design includes tools for design review, rapid prototyping, web publishing, validation checking, re-use

SIEMENS

[siemens.com/nx](https://www.siemens.com/nx)

Features *continued*

- Cornerstone of a complete product development system
- Foundation for product lifecycle management
- Extendible with a selection of add-on application modules
- Works with surface and facet geometry in the same CAD model

library and custom program execution. It also offers design-oriented stress and vibration analysis wizards. This solution includes the necessary tools to integrate to Teamcenter to provide powerful data management and visualization capabilities for product and process management.

NX Mach 2 Product Design

The Mach 2 Product Design package provides enhanced product design capabilities including flexible printed circuit board design, validation checking, user-defined features, rendering, 3D annotation for product and manufacturing information (PMI) and basic routing.

NX Mach 3 Product Design

The Mach 3 Product Design package provides a high-performance solution with NX capabilities for advanced assembly design, advanced freeform modeling and surface analysis, design optimization and molded part validation.

Enhancing basic design through production

NX Mach design software packages deliver comprehensive and scalable digital product development that addresses all stages of the product development process, from basic design through production.

The NX Mach packages transform the product development process and support dynamic change within organizations by:

- Increasing innovation throughout the product development process
- Eliminating waste by better utilizing time, material and intellectual resources
- Improving quality from the beginning

NX Mach design solutions offer key advantages:

- Unified solution – seamless application integration rapidly propagates changes to product and associated process information
- Teamcenter integration – all tools necessary to integrate with Teamcenter
- Knowledge-driven automation – re-use of product and process knowledge across all elements and phases of product development
- Integrated simulation and validation – comprehensive simulation and validation tools check product performance and manufacturability throughout every step of product development



	Mach 1 Product Design	Mach 2 Product Design	Mach 3 Product Design
Teamcenter			
Teamcenter integration for NX	•	•	•
Design modeling			
Feature-based solid modeling	•	•	•
Synchronous technology	•	•	•
Core Convergent Modeling	•	•	•
Drafting	•	•	•
Assemblies	•	•	•
Advanced assembly modeling			•
Basic freeform modeling	•	•	•
Advanced freeform modeling			•
User-defined features		•	•
Process-specific modeling tools			
Sheet metal design	•	•	•
PMI		•	•
Flexible PCB		•	•
Basic routing		•	•
Industrial design			
Photorealistic rendering		•	•
Visualize shape		•	•
Freeform shape			•
Advanced surface analysis			•
Product validation			
Product validation		•	•
HD3D Visual Reporting OOTB reports	•	•	•
HD3D Visual Reporting custom report editing			•
Optimization and sensitivity study tools		•	•
Molded part validation			•
Runtime licenses			
Runtime for custom program execution	•	•	•
Data exchange			
DXF/DWG, IGES, STEP 203/214, JT, Solid Edge open, SolidWorks open	•	•	•

NX Mach design capabilities

Teamcenter Integration for NX

NX offers full integration with Teamcenter software. The powerful data management system provides tools for vaulting, check-in/check-out, revision management, attribute synchronization and searching. It also includes data conversion capabilities for generating visualization files.

Design modeling

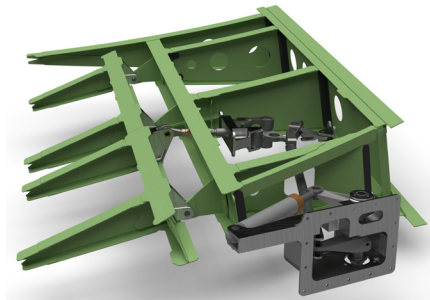

Feature-based solid modeling

The core modeling capability in NX combines wireframe, surface, solid, parametric and direct modeling in a single environment that enables designers to choose the most appropriate tool for the task at hand. NX delivers full feature-based parametric solid modeling and advanced features including blends, thin-wall, draft, mirrored features, open profile features and patterns. It provides support for the creation of 2D/3D wire-frame models, swept and revolved solids, Boolean operations and basic parametric editing. Included are variational sketching tools for quick and efficient conceptual design as well as tools for general modeling and editing tasks. Models retain the original parametric values and may be edited using intuitive dimension-driven techniques.

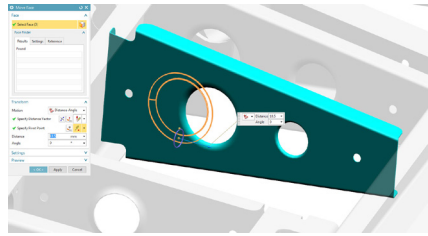

Synchronous technology

Direct modeling with synchronous technology offers a fast and intuitive approach to creating and editing designs using simple push-and-pull methods, and enables you to work directly with geometry created with other CAD systems. For greater versatility and design flexibility, you can use synchronous modeling interchangeably with all of the other modeling tools. A configurable, role-based user interface displays the commands you need as you need them, and grows as your experience level grows.

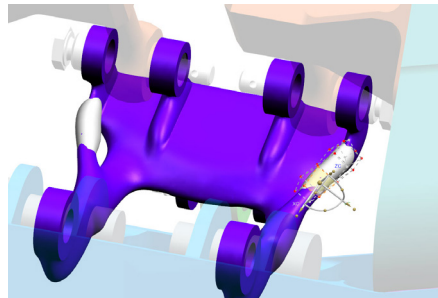

Core Convergent Modeling

Convergent Modeling is a game-changing technology for working with facet geometry. It is now possible to design with facet geometry using the same parametric, feature-based methods as used with traditional CAD geometry. Familiar feature-based modeling tools (Boolean, trim, offset, shell, scale, taper, blend, chamfer) can all be used when working with facet geometry. Designers can work with facet geometry in assembly modeling, drafting, PMI and other applications.

Drafting

NX drafting automates and streamlines engineering drawing production. Drawings are associative to models, so model changes automatically update and are reflected in related drawings. Drafting capabilities include dimensioning, symbols, tabular notes, sheet layout and placement of standard orthographic and auxiliary views, automatic view creation from the 3D model, hidden line processing and automatic parts list generation. Templates that include drawing borders and view layouts can be dragged and dropped into models to automate much of the work associated with manually created drawings. Drafting tools can be configured to comply with the drawing standard selected by the user – ANSI, ISO, JIS, DIN, GB and ESKD.

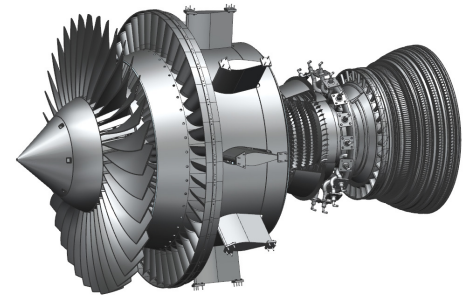

Assemblies

NX assemblies supports top-down and bottom-up assembly modeling. It supports the “design in context” approach where changes can be made to any component of the design model while working in the context of the assembly. Assemblies can be easily traversed using the assembly navigator in conjunction with intelligent component searching capabilities. NX assemblies also include support for creation of flexible assemblies and parts, enabling different arrangements and configurations of components such as springs and pistons.

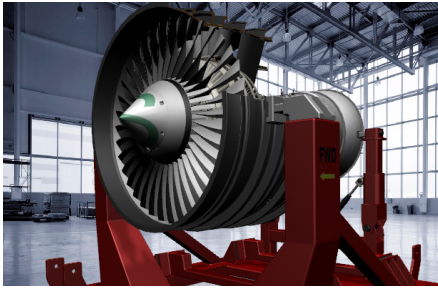

Advanced assembly modeling

The advanced assembly modeling capabilities in Mach 3 design packages enable you to simplify components or subassemblies into a single lightweight solid, to enclose assembly geometry in an envelope of planar faces, to partition assemblies into meaningful regions, and to manage weight and other mass properties of components and assemblies. Component filtering techniques enable designers to quickly identify and load the components of relevance to their current task, avoiding unnecessary delays and screen clutter caused by loading irrelevant components.

Basic freeform modeling

Basic freeform modeling is a core suite of tools for creating freeform solid or surface shapes from wireframe geometry. History-based parametric methods are included. Creation methods include offsets, extensions, rulings, lofts, sweeps, network and boundary fill. It also provides support for tangent and curvature-continuous shapes.

Advanced freeform modeling

Advanced freeform modeling extends the NX basic freeform capability to include shapes driven by laws and conics, blended shapes controlled by guiding curves, flange surfaces, guided construction of surfaces from facet meshes, midsurface construction and the ability to globally deform solid or surface shapes.

User-defined features

Designers using NX can capture and store families of features for easy retrieval, editing and re-use. User-defined features enable designers to establish relationships between parameters, define feature variables, set default values and decide the general form the feature will take. User-defined features reside in a re-use library that is accessible by anyone using NX modeling.

Process-specific modeling tools

Sheet metal design

NX provides solid modeling tools that are focused on design for manufacturing of sheet metal parts. Designers can create sheet metal component models using feature-based design tools for tabs, flanges and other typical features. Users can define forming tables and bend sequence tables, and flatten and reform the solid model, taking into account material deformation properties. The sheet metal tools generate accurate flat pattern data for downstream applications.

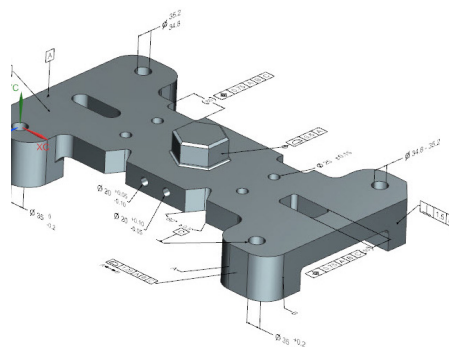

PMI

NX product and manufacturing information enables designers to digitally author 3D annotation and product data in a solid part or assembly. PMI includes 3D dimensions, geometric dimensioning and tolerancing (GD&T) data such as datums and feature control frames, 3D notes and customizable nongeometric information that can be directly associated to an NX model.

Flexible printed circuit board design

NX provides an environment for design of both flexible and rigid printed circuit boards (PCBs). The PCB design tools help model printed circuits rapidly and accurately in the context of an assembly and send the outlines to manufacturing or to an ECAD system for further refinement. The printed circuit model developed in NX can be checked for clearances and tolerances, and then the finished board model can be transferred to an ECAD system for further refinement, such as component placement or circuit trace or layer development.

Basic routing

NX Mach 2 and 3 deliver routing capabilities for designing pipe, tube and cable runs. The routing tools also enable intelligent part selection and placement of standard components such as elbows and tees. The routing capabilities can be extended by adding discipline-specific functionality for advanced applications including cabling, piping and tubing and heating, ventilation and air conditioning (HVAC) design.

Industrial design



Rendering

NX includes high-end, realistic and photorealistic display for communicating product designs. Using Advanced Studio to dynamically visualize and inspect realistic display of the designs throughout the design and manufacturing process helps to understand designs better, make better design decisions faster and shorten the design cycle for more innovation. Ray Traced Studio photorealistic rendering produces images for design reviews,

marketing or sales collateral, catalogs or manuals earlier in the process, speeding time to market. Libraries of physically-based materials and scenes with image-based lighting schemes are provided for easy setup. Editing tools enable designers to change them or create new ones. The studio task environment streamlines the rendering workflows with a concise set of tools and context-specific commands that streamline setup of rendered images.

Freeform shape

A comprehensive suite of tools for industrial design, styling and reverse engineering. With the tools designers can create freeform shapes of the highest quality (class-a), and develop styled primary, secondary and tertiary surfaces (styled sweeps, blends and corners). The tools fully support class-a working methods (surface shaping, fitting, snipping, and edge matching) to achieve up to G3 curvature continuity. With the reverse engineering capabilities designers can import facet scans into fully parametric traditional CAD models, detect shape from the facets (primitive and curvature-based), and fit curves and surfaces (planes, cylinders, cones, spheres, freeform) as parametrically editable features. The power of feature and synchronous modeling streamlines detailing and editing of designs.

Advanced surface analysis

A comprehensive suite of tools for checking that CAD models meet geometric, manufacturing and aesthetic quality standards. The tools check for deviation, continuity, draft, radius, curvature, highlights, reflections, gap and flushness.

Product validation

Check-Mate validation runtime

The Check-Mate tool enables customers to set up and enforce rules to monitor design integrity and improve product quality. This product validation tool includes various standard checks for files, models, drawings and assemblies. Results of validation checks can be delivered using HD3D Visual Reporting.

Optimization and sensitivity study tools

The optimization tool enables NX expressions to be varied algorithmically to drive a design objective toward a desired maximum or minimum value. The sensitivity study capability provides a way to systematically vary multiple selected NX expressions while logging one or more measurements to explore a given design space for viable design candidates.

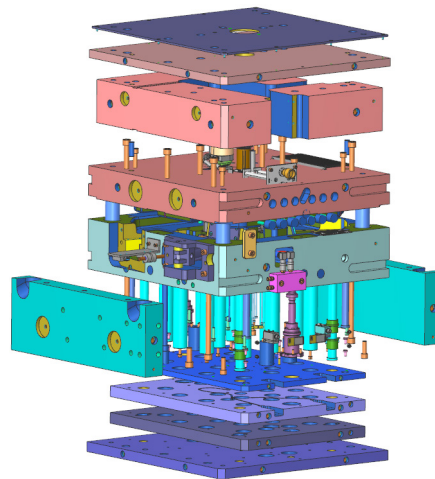

Molded part validation

NX Mach 3 packages include a molded part validation tool that enables designers to check the moldability, even if they know little about mold design. NX analyzes parts and automatically provides

designers with information about draft angles, undercut areas, sharp corners, small radiuses and other items that could compromise molding quality. It also provides designers with an easy visual check of core and cavity sides.

HD3D Visual Reporting

HD3D Visual Reporting software blends information of interest from your company's data sources directly into the 3D product design environment. This helps designers make unambiguous assessments, interpret information more accurately and synthesize product and process data rapidly into correct design decisions.

HD3D Visual Reporting comes with a set of predefined, out-of-the-box reports that provide design teams with answers to commonly asked questions. Reports related to ownership, check out, part maturity, projects, load status, validation status and more are available for instant use. With the authoring capability, companies can create and modify custom reports to extract and present the data.

Runtime licenses

Mach design packages can run applications created with our wide range of application programming interfaces (APIs).

Translators/interfaces

Data exchange

NX data exchange tools include the most commonly used translators needed to bring data into and out of NX, including IGES, STEP AP203, STEP AP214, DXF/DWG, STL and 3MF. These translators include geometry repair and simplification capabilities to ensure the most useful data possible. All of the translators can be run externally from NX or directly inside NX using “File Import/Export” and “File Open/Save As” commands or from the command line, making them customizable to any workflow.

**Siemens Digital
Industries Software**
[siemens.com/software](https://www.siemens.com/software)

Americas
1 800 498 5351

Europe
00 800 70002222

Asia-Pacific
001 800 03061910

For additional numbers,
click [here](#).